

Snatch Block Green Pin® type 601T P-6953

Product information



The Green Pin® Snatch Block is a light-weight snatch block type 601T. The snatch block has a smooth, uninterrupted pull due to its conical roller bearings. The coating of the Green Pin® Snatch Block ensures long-term durability, even under harsh conditions. The product is available in a range with a working load limit from 4 up to 8 ton.

These are equipped with bronze bushes.

Certification on request: 2.1, 2.2, MTCb

... [Read more](#)

Material: carbon steel, fitted with conical roller bearings

Marking: CE-marked

Finish: painted

Note: Working Load Limit is on the headfitting

Safety factor: 4:1

Snatch Block Green Pin® type 601T P-6953

Blueprint

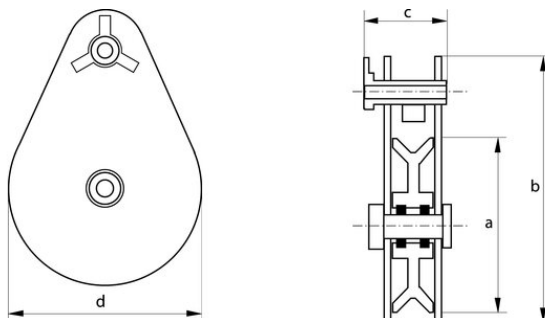

Technical data

Part code	Rope Ø range mm	WLL (metric) tonnes	Sheave dia mm	A in	B in	C in	D, in	Weight lb
424100400210	10-12	4	115	4.53	8.39	3.27	4.72	8.82
424100800210	20-22	8	152	5.98	12.01	4.25	6.3	19.84
424100800215	20-22	8	203	7.99	14.06	4.25	8.27	26.46
424100800216	20-22	8	254	10	15.98	4.25	10.24	35.27