

# Series 602/603 mini ratchet lever hoist

## Mini-Ratchet Lever Hoists lift up to 1100 lbs. plus the convenience of toolbox storage.

The CM Series 603 & 602 Mini-Hoists are the most compact ratchet lever hoists in the market, perform just like the larger models, plus come standard with these great features:

- Plated load chain is standard.
- Weston-type load brake.
- Rubber hand grip for better comfort and security.
- Lightweight design for ease of portability. Use in confined conditions with one-hand operation.
- Forged upper and lower hooks with latches standard.
- Impact resistant, all-steel frame, gear case and cover.
- Hardened link-type alloy steel load chain for strength and long wear.
- Free wheeling feature serves to quickly attach the load.
- Metric rated.



5 Ft. & 10 Ft. Lifts

### SPECIFICATIONS

Capacity (Lbs.)	Capacity (Kg.)	Model Number	Number of Chainfalls	Handle Length (In.)	Minimum Distance Between Hooks (In.)	Lift w/ One Full Lever Turn (In.)	Handle Pull @ W.L.L. (Lbs.)	Net Weight w/Standard Lift (Lbs.)
550	250	602	1	6.300	9.45	3.15	56	6.0
1100	500	603	1	6.375	11.125	1.57	78	7.0



*Our compact Mini-Hoists perform just like the larger hoists, except they're small enough to fit in the palm of your hand.*



Convenient Carry Bag - Product Code # 0212

# Series 602 mini ratchet lever hoist-Specifications

Dimensional Drawing - 602

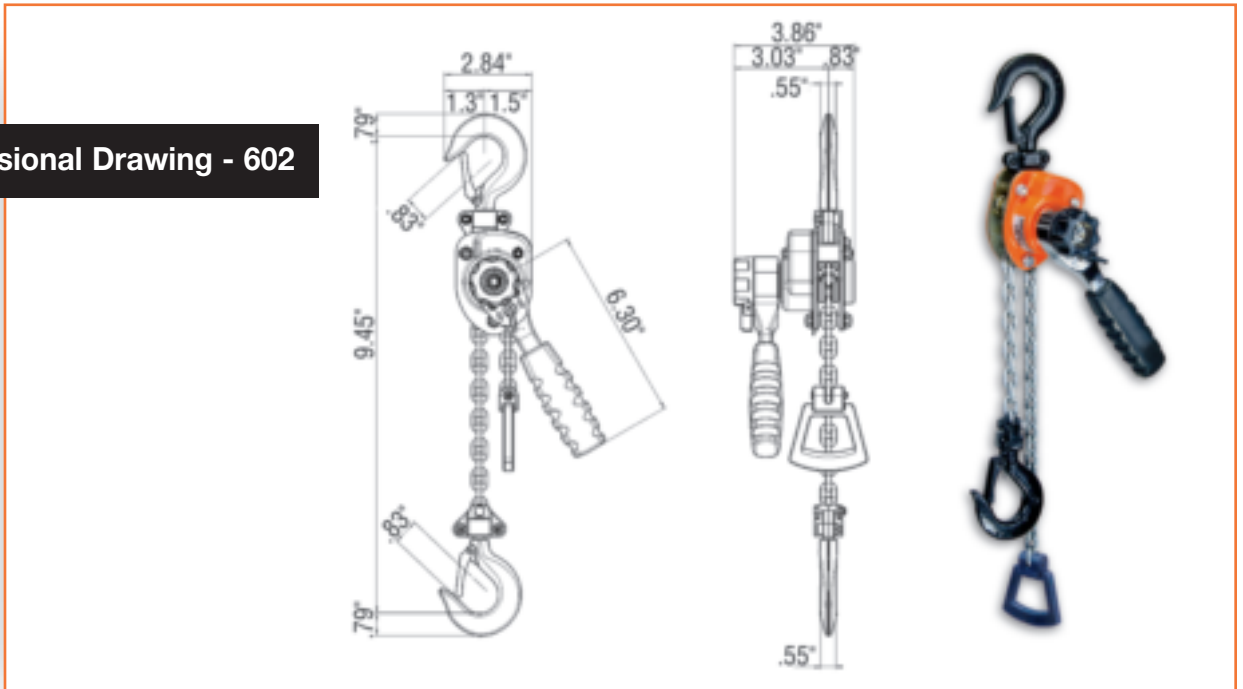

Dimensional Drawing - 603

