

# IMPORTANT - Read and understand these instructions before using eye bolts.

## Regular Nut & Shoulder Nut Eye Bolt - Installation for In-line Loading

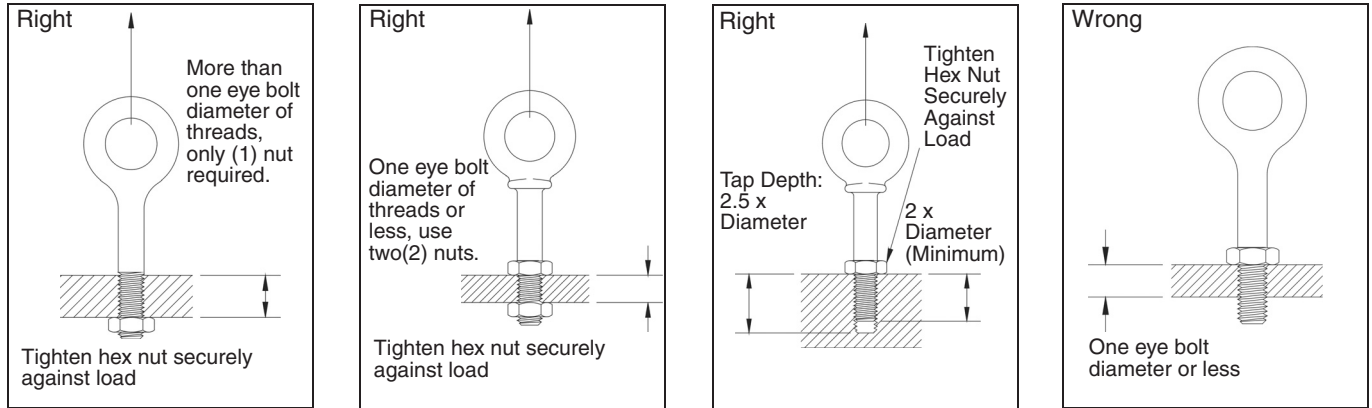

### Operating Safety

- Always stand clear of load.
- Always lift load with steady, even pull – do not jerk.
- Always apply load to eye bolt in the plane of the eye – not at an angle.
- Never exceed the capacity of the eye bolt—see Table I & 2.
- When using lifting slings of two or more legs, make sure the loads in the legs are calculated using the angle from the vertical to the leg and properly size the shoulder nut or machinery eye bolt for the angular load.

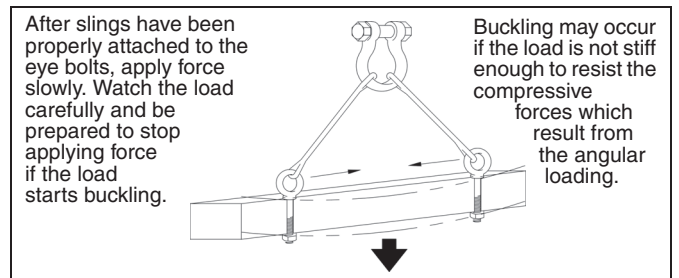
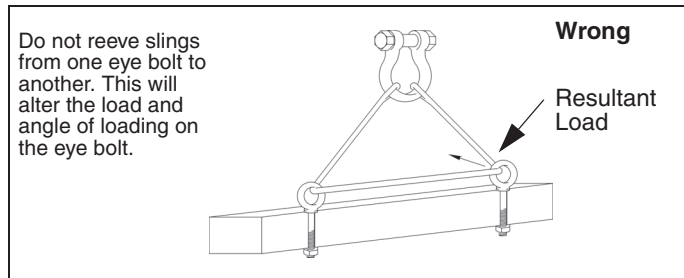

## Machinery Eye Bolt - Installation for In-line & Angular Loading

These eye bolts are primarily intended to be installed into tapped holes.

1. After the loads on the eye bolts have been calculated, select the proper size eye bolt for the job.

For angular lifts, adjust working load as follows:

Direction of Pull	Adjusted Working Load
45 degrees	30% of rated working load
90 degrees	25% of rated working load

2. Drill and tap the load to the correct sizes to a minimum depth of one-half the eye bolt size beyond the shank length of the machinery eye bolt.
3. Thread the eye bolt into the load until the shoulder is flush and securely tightened against the load.
4. If the plane of the machinery eye bolt is not aligned with the sling line, estimate the amount of unthreading rotation necessary to align the plane of the eye properly. Remove the machinery eye bolt from the load and add shims (washers) of proper thickness to adjust the angle of the plane of the eye to match the sling line. Use Table 3 to estimate the required shim thickness for the amount of unthreading rotation required.

Eye Bolt Size (in.)	Shim Thickness Required to Change Rotation 90° (in.)	Eye Bolt Size (mm)	Shim Thickness Required to change Rotation 90° (mm)
1/4	.0125	M6	.25
5/16	.0139	M8	.31
3/8	.0156	M10	.38
1/2	.0192	M12	.44
5/8	.0227	M16	.50
3/4	.0250	M20	.62
7/8	.0278	M24	.75
1	.0312	M27	.75
1-1/8	.0357	M30	.88
1-1/4	.0357	M36	1.00
1-1/2	.0417	—	—
1-3/4	0.500	M42	1.13
2	.0556	M48	1.25
2-1/2	.0625	M64	1.50

